

PART A (1 - 20)

1. A satellite is in elliptical orbit about the earth (radius = 6400 km). At perigee it has an altitude of 1100 km and at the apogee its altitude is 4100 km. The major axis of the orbit is ,
 (A) 5,200 km
 (B) 10,400 km
 (C) 11,600 km
 (D) 18,000 km

2. A cubical block of side a is moving with velocity v on a horizontal smooth plane as shown in fig. It hits a ridge at point O. The angular speed of the block after it hits O is

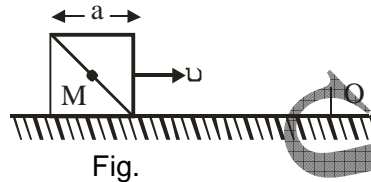

- (A) $3v / (4 a)$
 (B) $3v / (2 a)$
 (C) $\sqrt{3} v / (\sqrt{2} a)$
 (D) Zero
3. Water rises to a capillary tube to a height of 4 cm. If the area of cross-section of the tube is one fourth, the water will rise to a height of,
 (A) 2 cm
 (B) 4 cm
 (C) 8 cm
 (D) 16 cm
4. A spring of force constant k is cut into two pieces whose lengths are in the ratio 1 : 2. What is the force constant of the longer piece?
 (A) $\frac{k}{2}$
 (B) $\frac{3k}{2}$
 (C) k
 (D) $2k$
5. Two protons move parallel to each other with an equal velocity $v = 300$ km/sec. What is the ratio of forces of magnetic and electrical interaction of the protons.

- (A) 1×10^{-6}
- (B) 10×10^{-6}
- (C) 10×10^{-7}
- (D) None of these

6. A 22 cm long solenoid having total number of turns 1000, consists of a core of cross-sectional area 4 cm^2 . Half portion of the core consists of air and other half is made of iron of relative permeability 500. Calculate the self inductance of the solenoid.
- (A) 0.57 H
 - (B) 0.64 mH
 - (C) 0.057 H
 - (D) 57.0 H.
7. A liquid is poured into a vessel at rest with the hole in the wall closed. It is filled to a height H . With what horizontal acceleration should the vessel be moved so that the liquid does not come out, when the hold is opened ?

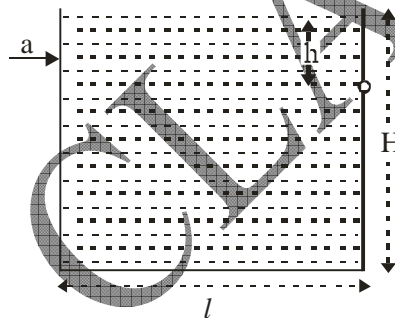

- (A) g
 - (B) $2g(H/l)$
 - (C) $2g(h/l)$
 - (D) $2g(H-h)/l$
8. Two bodies with moment of inertia I_1 and I_2 and ($I_1 > I_2$) have equal angular momenta. If K.E. of rotation are E_1 and E_2 , then
- (A) $E_1 < E_2$
 - (B) $E_1 > E_2$
 - (C) $E_1 = E_2$
 - (D) $E_1 = E_2$

9. Two blocks of masses 1 kg and 2 kg are connected by a metal wire going over a smooth pulley as shown in Fig. The breaking stress of the metal is $2 \times 10^9 \text{ N/m}^2$. If the wire do not break, then its minimum radius should be

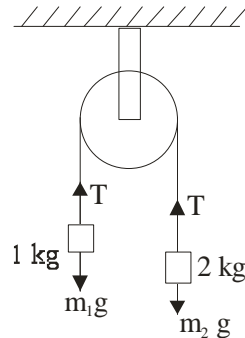

- (A) $4.6 \times 10^{-5} \text{ m}$
 (B) $6.4 \times 10^{-5} \text{ m}$
 (C) $4.6 \times 10^{-6} \text{ m}$
 (D) $6.4 \times 10^{-6} \text{ m}$
10. With what terminal velocity will an air bubble 0.8 mm in diameter rise in liquid of viscosity $0.15 \text{ Nm}^{-2} \text{ s}$ and specific gravity 0.9. Density of air = 10^3 kg/m^3 .
- (A) 0.021 m/s^2
 (B) 0.0021 m/s^2
 (C) 0.0128 m/s^2
 (D) 2.0223 m/s^2
11. A particle is moving in a space with origin 'O' then the correct expression of position vector and velocity in spherical polar coordinate is
- (A) Position vector $\vec{r} = r\hat{e}_r$, and velocity $\vec{v} = r\dot{\hat{e}}_r + r\dot{\theta}\hat{e}_\theta + \dot{\phi}\hat{e}_\phi$
 (B) Position vector $\vec{r} = r\hat{e}_r$ and velocity $\vec{v} = r\dot{\hat{e}}_r + r\dot{\theta}\hat{e}_\theta + r \sin\theta \dot{\phi}\hat{e}_\phi$
 (C) Position vector $\vec{r} = r\hat{e}_r + r\theta\hat{e}_\theta + \phi\hat{e}_\phi$ and velocity $\vec{v} = r\dot{\hat{e}}_r + r\dot{\theta}\hat{e}_\theta + r \sin\theta\dot{\phi}\hat{e}_\phi$
 (D) Position vector $\vec{r} = r\hat{e}_r + r\theta\hat{e}_\theta + \phi\hat{e}_\phi$ and velocity $\vec{v} = r\dot{\hat{e}}_r + r \sin\theta\dot{\hat{e}}_\theta + r \sin^2\theta\dot{\hat{e}}_\phi$
12. A ball is rising through a liquid with constant speed. The ratio of density of liquid to that of material of ball is 3 : 1. The ratio of viscous force to the weight of the ball is
- (A) 1 : 3

- (B) 2 : 1
 (C) 1 : 4
 (D) 4 : 1

13. A transverse wave is described by the equation $y = y_0 \sin 2\pi \left(ft - \frac{x}{\lambda} \right)$. The maximum particle velocity is equal to four times the wave velocity if

- (A) $\lambda = \frac{\pi y_0}{4}$
 (B) $\lambda = \frac{\pi y_0}{2}$
 (C) $\lambda = \pi y_0$
 (D) $\lambda = 2\pi y_0$

14. Monochromatic light of wavelength 5000\AA falls normally on a grating of 2cm wide. The first order spectrum is produced at an angle 30° from the normal. What is total number of lines on the grating

- (A) 40000
 (B) 20000
 (C) 25000
 (D) 35000

15. Monochromatic plane-polarized light with angular frequency ω passed through a certain substance along a uniform magnetic field H . Find the difference of refractive indices for right-hand and left-hand components of light beam with circular polarization if the verged constant is equal to V .

- (A) $\Delta n = \frac{2CVH}{\omega^2}$
 (B) $\Delta n = \frac{VH}{2\omega C}$
 (C) $\Delta n = \frac{2CVH}{\omega}$
 (D) $\Delta n = \frac{CVH}{2\omega}$

16. A given quantity of an ideal gas is at pressure P and absolute temperature T . The isothermal bulk modulus of gas is

- (A) $\frac{2}{3}P$

- (B) P
- (C) 2P
- (D) $\frac{3}{2}P$

17. What is the entropy increment of one mole of a vander waals gas due to the isothermal variation of volume from V_1 to V_2 .

(A) $R \ln \left[\frac{V_1 + \frac{a}{V_2}}{V_2 - \frac{a}{V_1}} \right]$

(B) $R \ln \left[\frac{V_2 - \frac{a}{V_2}}{V_1 + \frac{a}{V_1}} \right]$

(C) $R \ln \left(\frac{V_1 - b}{V_2 - b} \right)$

(D) $R \ln \left(\frac{V_2 - b}{V_1 - b} \right)$

18. $f(x)$ is a periodic function of x with period π and can be express as a fourier cosine series and $f(x) = \sin x$ then the coefficient of $\cos(4x)$ is

(A) $\frac{-\pi}{3}$

(B) $\frac{-\pi}{15}$

(C) $\frac{-1}{15\pi}$

(D) $\frac{1}{3\pi}$

19. Let a 3×3 matrix A have determinant 5, if $B = 4A^2$, then the determinant of B is equal to,

(A) 20

(B) 100

(C) 320

(D) 1600

20. A large number of liquid drops each of radius coalesce to form a single drop of radius R. The energy released in the process is converted into the kinetic energy of the big drop so

formed. The speed of the big drop is (given surface tension of liquid is T , density of liquid is ρ) .

(A) $\sqrt{\frac{6T}{\rho} \left(\frac{1}{r} - \frac{1}{R} \right)}$

(B) $\sqrt{\frac{4T}{\rho} \left(\frac{1}{r} - \frac{1}{R} \right)}$

(C) $\sqrt{\frac{6T}{\rho} \left(\frac{1}{r} + \frac{1}{R} \right)}$

(D) $\sqrt{\frac{4T}{\rho} \left(\frac{1}{r} + \frac{1}{R} \right)}$

PART B (21-40)

21. Two particles X and Y having equal charges, after being accelerated through the same potential difference, enter a region of uniform magnetic field and describe circular paths of radii R_1 and R_2 respectively. The ratio of the masses of X to that of Y is

(A) $(R_1/R_2)^{1/2}$

(B) R_2/R_1

(C) $(R_1 / R_2)^2$

(D) R_1 / R_2

22. A parallel beam of x-rays is diffracted by a rock salt crystal. The first-order strong reflection is obtained when the glancing angle (the angle between the crystal face and the beam) is $6^\circ 50'$. The distance between reflection planes in the crystal is 2.81 \AA . what is the wavelength of the x-rays ?

(A) 67 \AA

(B) 0.67 \AA

(C) 76 \AA

(D) 0.76 \AA

23. A particle describes a circular orbit under the influence of an attractive central force directed towards a point on the circle. The force is inversely proportional to .

(A) r^2

(B) r^3

- (C) r^4
(D) r^5

24. Two light waves having their intensities in the ratio 16:9 interfere to produce interference pattern. The ratio of maximum intensity to minimum intensity in this pattern will be.
(A) 4 : 19
(B) 49 : 1
(C) 1 : 49
(D) 49 : 9

25. One end of a long metallic wire of length L is tied to the ceiling. The other end is tied to a light spring of spring constant K . The mass m hangs freely from the free end of the spring. The area of cross section and the Young's modulus of the wire are A and Y respectively. If the mass is slightly pulled down and released, it will oscillate with time period equal to

- (A) $2\pi \sqrt{\frac{m}{k_s}}$
(B) $2\pi \sqrt{\frac{m}{k_s k_g}}$
(C) $2\pi \sqrt{\frac{k_s}{m}}$
(D) $\pi \sqrt{\frac{m}{k_s}}$

26.

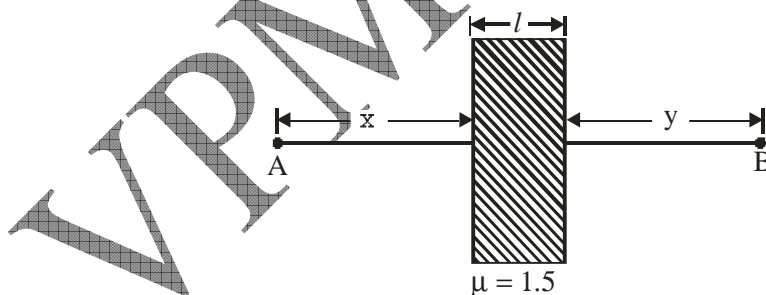

A slab of thickness t and refractive index 1.5 is placed in between points A and B as shown in the above figure. The optical path length between A and B is

(A) $3x + \frac{3}{2}t + y$

(B) $\frac{3}{2}x + t + y$

(C) $x + \frac{3}{2}t + 3y$

(D) $x + \frac{3}{2}t + y$

27. Electrons with de-Broglie wavelength λ fall on the target in an X-ray tube. The cut off wavelength of the emitted X-rays is.

(A) $\lambda_0 = \frac{2mc\lambda^2}{h}$

(B) $\lambda_0 = \frac{2h}{mc}$

(C) $\lambda_0 = \frac{2m^2c^2\lambda^3}{h^2}$

(D) $\lambda_0 = \lambda$

28. The first order reflection of a beam of X-rays of wavelength 1.84 \AA from the (100) face of a crystal of the simple cubic type occurs at an angle of 30° then the length of the unit cell is

(A) 1.59 \AA

(B) 3.60 \AA

(C) 1.84 \AA

(D) 0.92 \AA

29. The output voltage of an OPAMP for input voltage of $V_{i1} = 120 \mu\text{V}$, $V_{i2} = 100 \mu\text{V}$ if the amplifier has a differential gain of $A_d = 3000$ and the value of CMRR is 100 is

(A) 33.0 m volt

(B) 59.2 m volt

(C) 56.7 m volt

(D) 63.3 m volt

30. The truth table for the given circuit is

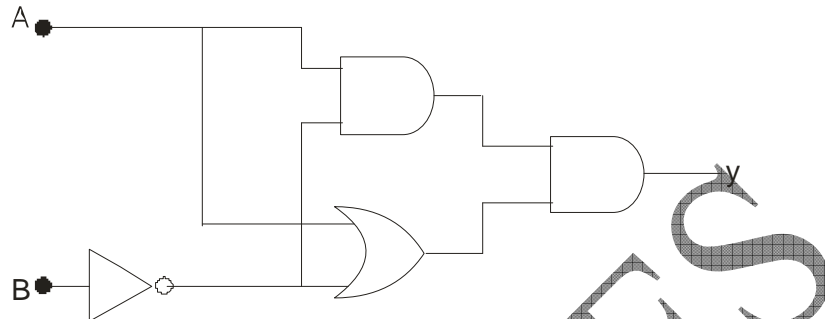

(A)

A	B	Y
0	0	0
0	1	0
1	0	1
1	1	0

(B)

A	B	Y
0	0	1
0	1	1
1	0	0
1	1	0

(C)

A	B	Y
0	0	1
0	1	0
1	0	0
1	1	1

(D)

A	B	Y
0	0	1
0	1	0
1	0	0
1	1	0

31. What is the self-inductance of a toroidal coil with rectangular cross section (inner radius a , outer radius b , height h), which carries a total of N turns.

(A) $\frac{\mu_0 N^2 h b}{2\pi a}$

- (B) $\frac{\mu_0 N^2 h}{2\pi} \ell n \frac{a}{b}$
- (C) $\frac{\mu_0 N^2 h}{2\pi} \frac{b^2}{a^2}$
- (D) $\frac{\mu_0 N^2 h}{2\pi} \ell n \left(\frac{b}{a} \right)$

32. EFGH is a thin square plate of uniform density σ and side $4a$. Four point masses, each of mass m , are placed on the plate as shown in the figure. In the moment of inertia matrix I of the composite system,

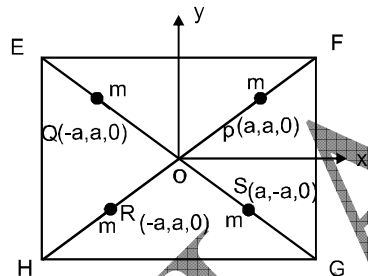

- (A) Only I_{xy} is zero
- (B) Only I_{xz} and I_{yz} are zero
- (C) All the product of inertia terms are zero
- (D) None of the product of inertia terms are zero
33. We have three energy levels in a system with at the temperature T . The Energies are 0 , ϵ and 3ϵ . They have the degeneracies of 1.5 and 8 respectively. What is the partition function for this system with k being the Boltzmann constant ?
- (A) $Z = 1 + 1.5 e^{\epsilon/KT} + 8 e^{3\epsilon/KT}$
- (B) $Z = 1 + 1.5 e^{-\epsilon/KT} + 8 e^{-3\epsilon/KT}$
- (C) $Z = 1 + e^{-\epsilon/KT} + e^{-29\epsilon/KT}$
- (D) $Z = 1 + e^{-5\epsilon/KT} + 8 e^{-24\epsilon/KT}$

34. A screen bearing a real image of magnification m_1 formed by a convex lens is moved a distance x . The object is then moved until a new image of magnification m_2 is formed on the screen. The focal length of the lens is

(A) $\frac{x}{m_2 - m_1}$

(B) $\frac{m_2 - m_1}{x}$

(C) $\frac{x}{m_1 - m_2}$

(D) $\frac{m_1 - m_2}{x}$

35. If waves in an ocean travel with a phase velocity $v_p = A\lambda^{-1/2}$, then what is the group velocity v_g of the 'wave packet' of these waves ?

(A) $v_g = (3/2)v_p$

(B) $v_g = (5/2)v_p$

(C) $v_g = (2/3)v_p$

(D) $v_g = (2/5)v_p$

36. Calculate the equivalent resistance between point A and B of following circuit. If a battery of internal resistance r is connected between A and B point, then for what value of R power loss become maximum ?

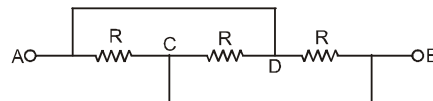

(A) $R' = \frac{R}{2}, R = \frac{2}{3}r$

(B) $R' = \frac{R}{3}, R = 3r$

(C) $R' = \frac{R}{4}, R = \frac{3}{2}r$

(D) $R' = \frac{R}{8}, R = 2r$

37. The stationary wave function of a particle confined to the interval $[0, a]$ on xOx is written as:

$$\Phi_n(x) = \sqrt{\frac{2}{a}} \sin\left(\frac{n\pi}{a}x\right), \quad n = 1, 2, 3, \dots$$

The energy corresponding to this particle is given by :

(A) $E_n = \frac{\pi^2 \hbar^2}{8ma^2} n^2$

(B) $E_n = \frac{\pi^2 \hbar^2}{2ma^2} n^2$

(C) $E_n = \frac{\pi^2 \hbar^2}{4ma^2} n^2$

(D) $E_n = \frac{\pi^2 \hbar^2}{ma^2} n^2$

38. What is the total charge of the system which gives rise to the electric field ?

$$E(x) = \frac{qe^{-\alpha r}}{r^3} \hat{x}$$

(A) 1

(B) 0

(C) $\frac{1}{4}$

(D) ∞

39. If 250 g of Ni at 120°C is dropped into 200 g of water at 10°C contained by a calorimeter of 20 cal/ $^\circ\text{C}$ heat capacity, what will be the final temperature of the mixture? (Given $C_{\text{Ni}} = 106\text{k cal}/^\circ\text{C}$)

- (A) $t = 20^\circ\text{C}$
- (B) $t = 65^\circ\text{C}$
- (C) $t = 22^\circ\text{C}$
- (D) $t = 60^\circ\text{C}$

40. If $f \propto -r^n$, then for what value of n , the circular orbit described is stable?

- (A) $n > 0$
- (B) $n > -1$
- (C) $n > -2$
- (D) $n > -3$

PART – C (41-50)

41. A 5.0 m long platform that weighs 600 N is held up by 2 ropes, each connected 1.0 m away from the edge of the platform. A man starts to load goods onto one end of the platform, placing the goods one on top of another such that the combined centre of gravity of the goods is always a horizontal distance of 0.6 m away from the edge of the platform.

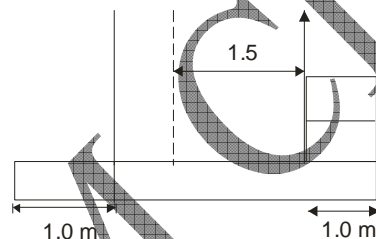

What is the maximum mass of goods that can be placed on the platform before the platform starts to tilt? What is the tension in the ropes when this maximum mass of goods has been loaded?

42. There are two vessels; each of them contains one mole of a monoatomic ideal gas. Initial volume of the gas in each vessel is $8.3 \times 10^{-3} \text{ m}^3$ at 27°C . Equal amount of heat is supplied to each vessel. In one of the vessels the volume of the gas is doubled without change in internal energy, whereas the volume of the gas is held constant in the second vessel. The

vessels are now connected to allow free mixing of the gas. Find the final temperature and pressure of the combined system if $R = 8.3 \text{ J/mol K}$.

43. The equation of state of a van der Waals gas is given by $\left(P + \frac{a}{V^2}\right)(V - b) = RT$
Calculate W , ΔU , Q and ΔH of this gas for an isothermal reversible expansion from an initial volume V_1 to a final volume V_2 .
44. Two moles of helium gas [$\gamma = 5/3$] are initially at temperature 27°C and occupy a volume 20 litres. The gas is first expanded at constant pressure until its volume is doubled. Then it undergoes an adiabatic change until the temperature returns to its initial value. (a) What are final volume and pressure of the gas?(b) What is the work done by the gas? [$R=8.3 \text{ J/mol K}$]
45. A piston divides a closed gas cylinder into two parts. Initially the piston is kept pressed such that one part has a pressure P and volume $5V$ and the other part has pressure $8P$ and volume V ; the piston is now left free. Find the new pressure and volume for the isothermal and adiabatic process [$\gamma = 1.5$].
46. A particle has a velocity $6 \times 10^7 \text{ m/sec}$ in the $X - Y$ plane at an angle of 60° with X - axis in the system S . Determine the magnitude and direction of its velocity in system S' . When S' has a velocity $3 \times 10^7 \text{ m/sec}$ along the positive x -axis.
- 47 Explain 'Zener breakdown'. The zener diode in the circuit shown below regulates at 50V , over a range of diode currents from 5 to 40mA . The supply voltage $V = 150\text{V}$. Compute the value of R to allow voltage regulation from a zero load current to a maximum load current I_{max} . What is I_{max} ?

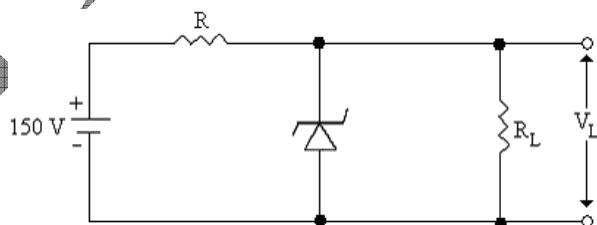

48. (a) The rest mass of the electron is 9.028×10^{-28} gm. Calculate the energy equivalent in electron volts.
 (b) The atomic mass unit is 1.6550×10^{-24} gm. Find the corresponding energy in electron volts.
49. A certain simple cubed structure has a cube edge of 4.85 \AA . Take the zero of energy to be at the bottom of the lowest free electron band
 (a) Assume the electrons are completely free and calculate the energy of the lowest energy state with propagation vector at the centre of a Brillouin Zone.
 (b) Suppose $u(G_1) = 0.24 \text{ eV}$, where G_1 is the reciprocal lattice vector perpendicular to the Brillouin zone face of part(a). Calculate the energy of the two lowest nearly free electron states with the propagative vector used in (a).
50. A BJT circuit has $\beta = 50$ and $V_{cc} = 20$ volt and uses a potential divider bias circuit with $R_c = 21 \text{ k}\Omega$, $R_e = 0.1 \text{ k}\Omega$, $R_1 = 100 \text{ k}\Omega$ and $R_2 = 5 \text{ k}\Omega$. Find the Q point.
 Assume $V_{be} = 0.2 \text{ V}$.

ANSWER KEY

Question	1	2	3	4	5	6	7	8	9	10	11	12	13	14	15
Answer	D	A	C	B	A	A	C	A	C	B	B	B	B	B	C
Question	16	17	18	19	20	21	22	23	24	25	26	27	28	29	30
Answer	B	D	B	D	A	C	B	D	B	A	D	A	C	D	A
Question	31	32	33	34	35	36	37	38	39	40					
Answer	D	C	B	A	A	B	B	B	C	D					

HINTS AND SOLUTION

- 1.(D) If a is semimajor axis of the ellipse, then the velocity is given as

$$v^2 = \mu \left[\frac{2}{r} - \frac{1}{a} \right]$$

By the property of ellipse

major axis $2a =$ maximum distance + minimum distance

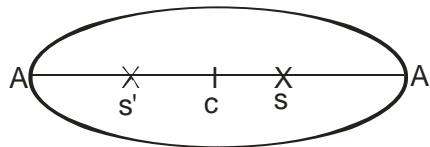

Maximum distance = maximum altitude + radius of earth
 $= (4100 + 6400)$

Minimum distance from centre of earth = $6400 + 1100$

So, $2a = (4100 + 6400) + (6400 + 1100) = 18000 \text{ km}$

2.(A) See fig. Here angular momentum about O is conserved.

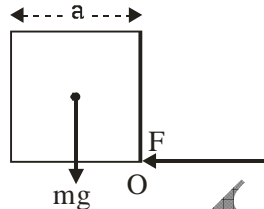

fig.

$$m v (1/2) = I_o \omega$$

where $I_o = I_{C.M.} + m(OC^2) = \frac{ma^2}{6} + m\left(\frac{a}{\sqrt{2}}\right)^2 = \frac{2ma^2}{3}$

$$\therefore \frac{m v a}{2} = \frac{2ma^2}{3} \times \omega$$

or $\omega = \frac{3v}{4a}$

3.(C) $h = \frac{2T \cos \theta}{\rho r g}$ or $h \propto \frac{1}{r}$

When area of cross section becomes one fourth, the radius is halved and hence h is doubled i.e., 8 cm.

4.(B) Here force constant $k = \frac{F}{\Delta \ell}$ when wire is cut, its two parts have length $\frac{2}{3}\ell$ and $\frac{1}{3}\ell$ and

extensions will also be $\frac{2}{3}\Delta \ell$ and $\frac{1}{3}\Delta \ell$. For the longer portion $k' = \frac{F}{2/3\Delta \ell} = \frac{3}{2} \frac{F}{\Delta \ell} = \frac{3}{2} k$

5.(A) The force of magnetic induction is given by

$$F_{\text{mag}} = e (v \times B)$$

Here $B = \frac{\mu_0}{4\pi} \frac{e(v \times r)}{r^3}$

$$\begin{aligned} \therefore F_{\text{mag}} &= \frac{\mu_0}{4\pi} \times \frac{e^2}{r^3} [v \times (v \times r)] \\ &= \frac{\mu_0}{4\pi} \times \frac{e^2}{r^3} [(v \cdot r) \times v - (v \cdot v) \times r] \\ &= \frac{\mu_0}{4\pi} \frac{e^2}{r^3} \times (-v^2 r) \end{aligned}$$

$$F_{\text{ele.}} = e E = e \frac{1}{4\pi\epsilon_0} \frac{e r}{r^3}$$

$$\therefore \frac{|F_{\text{mag}}|}{|F_{\text{ele.}}|} = -v^2 \mu_0 \epsilon_0 = \left(\frac{v}{c}\right)^2 = 1.00 \times 10^{-6}$$

6.(A) Magnetic field at the centre of solenoid is

$$B = \mu_0 Ni / \ell \text{ here } N = 1000$$

\therefore Magnetic flux linked with solenoid is

$$\phi = NBA = \frac{\mu_0 N^2 A}{\ell} i$$

Also $\phi = Li$

$$\therefore L = \frac{\mu N^2 A}{\ell}$$

Because the core consists of two mediums, so self induction is

$$\begin{aligned} L &= L_1 + L_2 \\ &= \frac{\mu_1 N^2 A_1}{\ell} + \frac{\mu_2 N^2 \cdot A_2}{\ell} \end{aligned}$$

For air $\mu_1 = \mu_0$ & for medium,

$$\mu_2 = \mu_r \mu_0, \text{ where } \mu_r = 500.$$

$$\therefore L = \frac{\mu_0 N^2}{\ell} [A_1 + \mu_r A_2] = 0.57 \text{ H.}$$

7.(C) If ρ be the density of liquid, then

$$\begin{aligned} F &= \frac{d(mv)}{dt} = v \frac{dm}{dt} \\ &= \frac{v d(V\rho)}{dt} = v\rho \frac{dV}{dt} \\ &= v\rho (\text{volume flowing per second}) \\ &= v\rho (A v) = v^2 A \rho \end{aligned}$$

$$= (2 g h) A \rho \quad (\because v = \sqrt{2 g h}) \quad \dots(1)$$

The mass of water on which this force acts

$$m = A l \rho$$

$$\therefore a = \frac{F}{m} = \frac{2 g h A \rho}{A l \rho} = \frac{2 g h}{l}$$

8.(A) Here, $E_1 = \frac{1}{2} I_1 \omega_1^2$ and $E_2 = \frac{1}{2} I_2 \omega_2^2$

$$\therefore \frac{E_1}{E_2} = \frac{I_1 \omega_1^2}{I_2 \omega_2^2} \quad \dots(1)$$

Given that, $I_1 \omega_1 = I_2 \omega_2$

Squaring, $I_1^2 \omega_1^2 = I_2^2 \omega_2^2$

or $\frac{I_1 \omega_1^2}{I_2 \omega_2^2} = \frac{I_2}{I_1} \quad \dots(2)$

From eqs. (1) and (2), we get

$$\frac{E_1}{E_2} = \frac{I_2}{I_1} < 1 \quad (\because I_1 > I_2)$$

$$\therefore E_1 < E_2$$

9.(C)

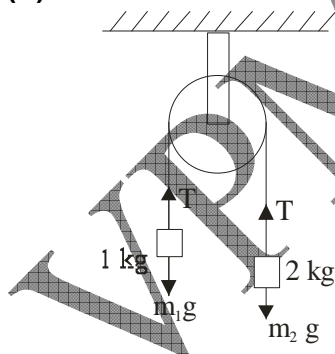

The equation of motion of two blocks are

$$T - 10 = 1 \times a$$

$$20 - T = 2 \times a$$

Solving we get, $T = (40/3)$ newton

$$\therefore \text{Stress} = \frac{(40/3)}{\pi r^2}$$

(\therefore Stress = Tension / area of cross section)

$$\text{Now } 2 \times 10^9 = \frac{(40/3)}{\pi r^2}$$

$$r = 4.6 \times 10^{-6} \text{ m}$$

10.(B) Here $r = 0.4 \text{ mm} = 4 \times 10^{-3} \text{ m}$.

$$\sigma = 0.9 \times 10^3 \text{ kg/m}^3, \rho = 10^3 \text{ kg/m}^3$$

$$\eta = 0.15 \text{ Nm}^{-2}\text{s} \text{ and } g = 9.8 \text{ m/s}^2$$

We know that

$$v = \frac{2}{9} \frac{g r^2 (\rho - \sigma)}{\eta}$$

$$= \frac{2}{9} \times \frac{9.8 \times (4 \times 10^{-3})^2 \times (10^3 - 0.9 \times 10^3)}{0.15} = 0.0021 \text{ m/s}^2$$

11.(B) In spherical polar coordinate position vector

$$\vec{r} = x\hat{i} + y\hat{j} + z\hat{k}$$

$$\vec{r} = r \sin\theta \cos\phi \hat{i} + r \sin\theta \sin\phi \hat{j} + r \cos\theta \hat{k}$$

$$\hat{e}_r = \sin\theta \cos\phi \hat{i} + \sin\theta \sin\phi \hat{j} + \cos\theta \hat{k}$$

$$\hat{e}_\theta = \cos\theta \cos\phi \hat{i} + \cos\theta \sin\phi \hat{j} - \sin\theta \hat{k}$$

$$\hat{e}_\phi = -\sin\phi \hat{i} + \cos\phi \hat{j}$$

so, $\vec{r} = r\hat{e}_r$

and velocity $\vec{v} = \dot{r} = \dot{r}\hat{e}_r + r\dot{\hat{e}}_r$

$$\vec{v} = \dot{r}\hat{e}_r + r\dot{\theta}\hat{e}_\theta + r\sin\theta\dot{\phi}\hat{e}_\phi$$

12.(B) Here $6\pi\eta r v + \frac{4}{3}\pi r^3 \rho g = \frac{4}{3}\pi r^3 \rho g$

or $6\pi\eta r v = \frac{4}{3}\pi r^3 \times 2\rho \cdot g = \frac{8}{3}\pi r^3 \rho g$

$$\text{Ratio } \frac{F}{W} = \frac{\frac{8}{3}\pi r^3 \rho g}{\frac{4}{3}\pi r^3 \rho g} = \frac{2}{1}$$

13.(B) $y = y_0 \sin 2\pi \left[ft - \frac{x}{\lambda} \right]$

We know wave velocity $v = \frac{\text{coefficient of } t}{\text{coefficient of } x} = \frac{2\pi f}{\frac{2\pi}{\lambda}} = \lambda f$

$$v = \lambda f \quad \dots(1)$$

Maximum particle velocity $v_{pm} = \omega A = 2\pi f y_0$

Given $v_{pm} = 4v$

$$\Rightarrow 2\pi f y_0 = 4[\lambda f]$$

$$\pi y_0 = 2\lambda$$

$$\Rightarrow \lambda = \frac{\pi y_0}{2}$$

14.(B) $(a + b) \sin\theta = n\lambda \quad (n = 1)$

$$(a + b) = \frac{\lambda}{\sin\theta} = \frac{5000 \times 10^{-8} \text{ cm}}{\sin 30^\circ} = 10000 \times 10^{-8} \text{ cm.}$$

$$(a + b) = 1 \times 10^{-4} \text{ cm}$$

So, the number of lines per cm on the grating $= \frac{1}{(a + b)} = \frac{1}{10^{-4}} = 10^4 \text{ cm}^{-1}$

But it is given that grating is 2cm. wide so total number of lines upon it is given by

$$= 2 \times 10^4 \\ = 2 \times 10^4 = 20000$$

15.(C) Since the difference in the refractive indices is given as

$$\delta = 2\pi(n_e - n_o)l/\lambda$$

$$\text{or} \quad = (n_e - n_o) 2\pi l / (c/v)$$

$$\text{or,} \quad = \Delta n l \cdot 2\pi v / c$$

$$\text{or,} \quad \delta = \Delta n l \omega / c$$

For circular polarization $\delta = \pi/2$

$$\text{so,} \quad \pi/2 = \Delta n l \omega / c \quad \dots(1)$$

And the angular rotation is given as

$$\phi_{\text{mag}} = \pi/4$$

$$\text{since,} \quad \phi_{\text{mag}} = V l H$$

$$\text{so,} \quad \pi/4 = V l H \quad \dots(2)$$

$$\text{so,} \quad 1/2 = (V l H) / (\Delta n l \omega / c)$$

$$\text{or,} \quad \Delta n = 2cVH/\omega$$

16.(B) ∴ PV = constant

$$PdV = VdP$$

$$\frac{dP}{dV} = -\frac{P}{V}$$

$$\text{Bulk Modulus } K = \frac{-dP}{\frac{dV}{V}} = -\frac{dP}{dV} V = -\left[\frac{-P}{V}\right] V = P$$

17.(D) We know vander waals gas equation is

$$\left[P + \frac{a}{V^2}\right][V - b] = RT \quad \dots(1)$$

The entropy change along an isothermal process can be written as

$$\Delta S = \int_{V_1}^{V_2} \left(\frac{\partial S}{\partial V}\right)_T dV \quad \dots(2)$$

from equation (1)

$$\therefore \left(\frac{\partial S}{\partial V}\right)_T = \left(\frac{\partial P}{\partial T}\right)_V = \frac{R}{V - b}$$

$$\text{So, } \Delta S = R \int_{V_1}^{V_2} \frac{1}{(V - b)} dV = R[\ln(V - b)]_{V_1}^{V_2}$$

18.(B) $f(x) = \sin x$

$$f(x) = A_0 + \sum_{n=1}^{\infty} A_n \cos nx \quad \dots(1)$$

$$A_0 = \frac{1}{\pi} \int_0^{\pi} f(x) dx \Rightarrow A_n = \frac{2}{\pi} \quad \dots(2)$$

$$A_n = \frac{1}{\pi} \int_0^{\pi} f(x) \cos nx dx = \frac{1}{2\pi} \int_0^{\pi} [\sin(n+1)x - \sin(n-1)x] dx$$

$$= \frac{1}{2\pi} \left[\frac{1}{(n+1)} \{\cos 0 - \cos(n+1)\pi\} + \frac{1}{(n-1)} \{\cos(n-1)\pi \cos 0\} \right]$$

$$A_n = \frac{1}{2\pi} \left[\frac{1}{(n+1)} \{1 - \cos(n+1)\pi\} - \frac{1}{n-1} \{1 - \cos(n-1)\pi\} \right]$$

for n odd $\cos(n+1)\pi = \cos(n-1)\pi = 1$

$$\Rightarrow A_n = 0$$

for n even $\cos(n+1)\pi = \cos(n-1)\pi = -1$

$$A_n = \frac{-\pi}{n^2 - 1} \quad \dots(3)$$

$$\text{So, } f(x) = \frac{2}{\pi} - \frac{\pi}{3} \cos 2x - \frac{\pi}{15} \cos 4x - \frac{\pi}{35} \cos 6x$$

$$\text{so coefficient of } \cos(4x) \text{ is } \frac{-\pi}{15}$$

19.(D) Here A is a 3×3 matrix
and $|A| = 5$

$$B = 4A^2$$

Since A is a matrix of order 3

$$B = 4^2 |A|^2$$

$$= 64 \times 25$$

$$\boxed{B = 1600}$$

20.(A) As the volume remains the same, we have

$$\frac{4}{3} \pi R^3 = n \left(\frac{4}{3} \pi r^3 \right) \quad \text{or} \quad R^3 = n r^3 \quad \dots(1)$$

Work done $W = T \times \Delta A$

$$= T [4 \pi r^2 n - 4 \pi R^2]$$

$$\text{or} \quad W = T 4 \pi [n r^2 - R^2] \quad \dots(2)$$

$$\text{Further, } W = \frac{1}{2} m v^2 = \frac{1}{2} \left(\frac{4}{3} \pi R^3 \rho \right) v^2 \quad \dots(3)$$

From eqs. (2) and (3), we have

$$\frac{1}{2} \left(\frac{4}{3} \pi R^3 \rho \right) v^2 = T 4 \pi [n r^2 - R^2]$$

$$v^2 = \frac{6T}{\rho} \left[\frac{n r^2}{R^3} - \frac{R^2}{R^3} \right]$$

$$v = \sqrt{\frac{6T}{\rho} \left[\frac{n r^2}{n r^3} - \frac{1}{R} \right]}$$

$$\text{or} \quad v = \sqrt{\frac{6T}{\rho} \left[\frac{1}{r} - \frac{1}{R} \right]}$$

21.(C) Let R_1 and R_2 be the radius of the circular paths described by the particles X and Y respectively in uniform magnetic field B. Then

$$\frac{m_1 v_1^2}{R_1} = q v_1 B \quad \text{or} \quad \frac{m_1 v_1}{R_1} = q B$$

and

$$\frac{m_2 v_2^2}{R_2} = q v_2 B \quad \text{or} \quad \frac{m_2 v_2}{R_2} = q B$$

$$\therefore \frac{m_1 v_1}{R_1} = \frac{m_2 v_2}{R_2} \text{ or } \frac{m_1}{m_2} = \left(\frac{R_1}{R_2}\right) \left(\frac{v_2}{v_1}\right) \quad \dots(1)$$

As they are accelerated by the same potential, the K.E. acquired by them will be the same.

$$\text{Hence } \frac{1}{2} m_1 v_1^2 = \frac{1}{2} m_2 v_2^2 \quad \text{or} \quad m_1 v_1^2 = m_2 v_2^2$$

$$\left(\frac{m_1}{m_2}\right) = \left(\frac{v_2}{v_1}\right)^2 \text{ or } \frac{v_2}{v_1} = \sqrt{\left(\frac{m_1}{m_2}\right)} \quad \dots(2)$$

Substituting the value of (v_2 / v_1) from eq. (2) in eq.(1), We get

$$\frac{m_1}{m_2} = \left(\frac{R_1}{R_2}\right) \sqrt{\left(\frac{m_1}{m_2}\right)} \text{ or } \sqrt{\frac{m_1}{m_2}} = \left(\frac{R_1}{R_2}\right)$$

$$\text{or } \frac{m_1}{m_2} = \left(\frac{R_1}{R_2}\right)^2$$

22.(B) This is an application of Bragg's reflection law, $m\lambda = 2d \sin \phi$, where ϕ is the glancing angle, not the angle of incidence. For $m = 1$

$$\lambda = \frac{2d \sin \phi_1}{1} = \frac{(2)(2.81 \text{ \AA})(0.119)}{1} = 0.67 \text{ \AA}$$

23.(D) For attractive central force,

$$r = \frac{1}{u} = 2a \cos \theta$$

$$\text{So, } u = \frac{\sec \theta}{2a} \quad \dots(1)$$

$$\Rightarrow \frac{d^2 u}{d\theta^2} = \frac{\sec^3 \theta + \sec \theta \tan^2 \theta}{2a} \quad \dots(2)$$

Now substitute equation (2) in equation of orbit

$$\begin{aligned} f\left(\frac{1}{u}\right) &= -\frac{l^2 u^2}{m} \left(\frac{d^2 u}{d\theta^2} + u\right) \\ &= -\frac{l^2 u^2}{2am} [\sec^3 \theta + \sec \theta \tan^2 \theta] \\ &= -\frac{l^2 \sec^3 \theta}{am} \cdot u^2 \end{aligned}$$

and from equation (1),

$$\sec \theta = 2au$$

$$\begin{aligned} \Rightarrow f\left(\frac{1}{u}\right) &= -\frac{l^2}{am} 8a^3 u^3 \cdot u^2 \\ &= -\frac{8a^2 l^2}{m} \cdot u^5 \\ &\propto u^5 \end{aligned}$$

or $f(r) \propto \frac{1}{r^5}$

24.(B) If I_1 and I_2 are intensities of two waves then ,

$$\begin{aligned} \frac{I_{max}}{I_{min}} &= \left[\frac{\sqrt{I_1} + \sqrt{I_2}}{\sqrt{I_1} - \sqrt{I_2}} \right]^2 \\ &= \left[\frac{\sqrt{(I_1/I_2)} + 1}{\sqrt{(I_1/I_2)} - 1} \right]^2 \end{aligned}$$

Since ,

$$\begin{aligned} \frac{I_1}{I_2} &= \frac{16}{9} \\ &= \left(\frac{\sqrt{16/9} + 1}{\sqrt{16/9} - 1} \right)^2 \\ &= \left(\frac{4/3 + 1}{4/3 - 1} \right)^2 \\ &= \left(\frac{7/3}{1/3} \right)^2 = \left(\frac{7}{1} \right)^2 = 49 : 1 \end{aligned}$$

25.(A) $F = \frac{YA}{L} x$

$$\Rightarrow F = k'x$$

$$\Rightarrow k' = \frac{YA}{L}$$

The spring has a force constant K and is connected in series with the wire. So equivalent force constant for series combination is

$$\Rightarrow k_s = \frac{Kk'}{K+k'}$$

$$\Rightarrow T = 2\pi \sqrt{\frac{m}{k_s}}$$

26.(D) The optical path of ray in a medium of thickness t and refractive index μ is given as

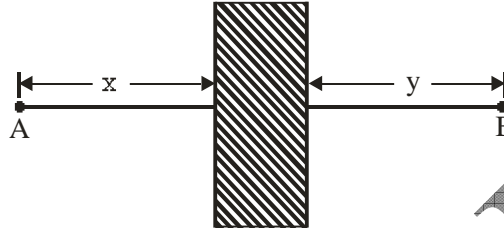

Optical path = μt

where $\mu = \frac{3}{2}$

So, total path

$$= x + \mu t + y$$

$$= x + \frac{3}{2}t + y$$

27.(A) $\lambda_0 = \frac{2mc\lambda^2}{h}$

According to de Broglie statement

$$P = \frac{h}{\lambda}$$

K.E. of striking electrons

$$K = \frac{P^2}{2m} = \frac{h^2}{2m\lambda^2}$$

this is also, maximum energy of X-ray photons

So, $\frac{hc}{\lambda_0} = \frac{h^2}{2m\lambda^2}$

So, $\lambda_0 = \frac{2m\lambda^2c}{h}$

28.(C) From Bragg's diffraction equation

$$2d \sin\theta = n\lambda$$

$$\theta = 30^\circ \quad \lambda = 1.84 \text{ \AA}$$

$$(hkl) = (100)$$

So, $d_{hkl} = \frac{a}{\sqrt{h^2 + k^2 + l^2}} = a$

So $2a \sin 30^\circ = 1 \times 1.84 \text{ \AA}$

$$2a \times \frac{1}{2} = 1.84 \text{ \AA}$$

$$\Rightarrow a = 1.84 \text{ \AA}$$

29.(D) $V_0 = A_d V_d + A_c V_c$

$$V_0 = A_d V_d \left[1 + \frac{A_c}{A_d} \frac{V_c}{V_d} \right]$$

$$\therefore \text{CMRR} = \frac{A_d}{A_c}$$

so, $V_0 = A_d V_d \left[1 + \frac{1}{\text{CMRR}} \frac{V_c}{V_d} \right]$ (1)

$$\therefore V_{i1} = 120 \mu\text{V} \quad V_{i2} = 100 \mu\text{V}$$

$$V_d = V_{i1} - V_{i2} = 20 \mu\text{V}$$

$$V_c = V_{i1} + \frac{V_{i2}}{2}$$

$$V_c = 110 \mu\text{V}$$

Given $A_d = 3000$

$$\text{CMRR} = 100$$

So, $V_0 = 3000(20 \mu\text{V}) \left[1 + \frac{1}{100} \left[\frac{110}{20} \right] \right] = (6 \times 10^3) [1 + 0.055] = 6.33 \times 10^{-2} \text{ volt}$

$$V_0 = 63.3 \times 10^{-3} \text{ V} = 63.3 \text{ mV}$$

30.(A) From logic diagram.

$$Y = (A\bar{B}) \cdot (A + \bar{B})$$

$$= A\bar{B}A + A\bar{B}\bar{B} = A\bar{B} + A\bar{B}$$

$$Y = A\bar{B}$$

So, if

$A = 0, B = 0 \Rightarrow$	$Y = 0.1 = 0$
$A = 0, B = 1 \Rightarrow$	$Y = 0.0 = 0$
$A = 1, B = 0 \Rightarrow$	$Y = 1.1 = 1$
$A = 1, B = 1 \Rightarrow$	$Y = 1.0 = 0$

31.(D) The magnetic field inside the toroid is Eq.

$$B = \frac{\mu_0 N I}{2\pi r}$$

The flux through a single turn Fig. is

$$\int B \cdot da = \frac{\mu_0 N I}{2\pi} h \int_a^b \frac{1}{s} ds = \frac{\mu_0 N I h}{2\pi} \ln \left(\frac{b}{a} \right)$$

The total flux is N times this, so the self-inductance Eq. is

$$L = \frac{\mu_0 N^2 h}{2\pi} \ln\left(\frac{b}{a}\right).$$

32.(C) $P = (a, a, 0)$ $Q = (-a, a, 0)$

$R = (-a, -a, 0)$ $S = (a, -a, 0)$

all have same mass 'm' have uniform density σ . We know component of inertia tensor are -

$$I_{xx} = \sum_{i=1}^4 m(y_i^2 + z_i^2) = m[a^2 + a^2 + a^2 + a^2 + 0 + 0 + 0 + 0] = 4m a^2$$

$$I_{xx} = 4ma^2$$

$$I_{yy} = \sum_{i=1}^4 m(x_i^2 + z_i^2) = m[a^2 + a^2 + a^2 + a^2 + 0 + 0 + 0 + 0]$$

$$I_{yy} = 4ma^2$$

$$I_{zz} = \sum_{i=1}^4 m(x_i^2 + y_i^2) = m[a^2 + a^2 + a^2 + a^2 + a^2 + a^2 + a^2 + a^2]$$

$$I_{zz} = 8ma^2$$

$$I_{xy} = -\sum_{i=1}^4 mx_i y_i = m[a^2 - a^2 + a^2 - a^2]$$

$$I_{xy} = 0$$

$$I_{yz} = -\sum_{i=1}^4 my_i z_i = -m[0 + 0 + 0 + 0]$$

$$I_{yz} = 0$$

$$I_{zx} = -\sum_{i=1}^4 mx_i z_i = 0$$

$$I_{zx} = 0$$

So, the component of principle axis is not zero but all the product of inertia terms are zero.

33.(B) The partition function is written as

$$z = \sum_n g_n e^{-\epsilon_n/KT}$$

where g_n is the degeneracy of the level and T is the temperature.

So,
$$z = 1e^{-0} + 1.5e^{-\epsilon/KT} + 8e^{-3\epsilon/KT}$$

$$z = 1 + 1.5 e^{-\epsilon/KT} + 8 e^{-3\epsilon/KT}$$

34.(A) In first case

$$\frac{1}{v} + \frac{1}{u} = \frac{1}{f} \quad \dots(1)$$

and
$$\frac{v}{u} = m_1 \quad \dots(2)$$

In second case,
$$\frac{1}{v+x} + \frac{1}{u'} = \frac{1}{f} \quad \dots(3)$$

and
$$\frac{v+x}{v'} = m_2 \quad \dots(4)$$

From eqs. (1), $1 + \frac{v}{u} = \frac{v}{f}$ or $1 + m_1 = \frac{v}{f} \quad \dots(5)$

Similarly from eqs. (3) and (4)

$$1 + m_2 = \frac{v+x}{f} \quad \dots(6)$$

Subtracting eq. (5) from eq. (6) we get

$$m_2 - m_1 = \frac{x}{f} \quad \text{or} \quad f = \frac{x}{m_2 - m_1}$$

35.(A) The phase velocity $v_p = A\lambda^{-\frac{1}{2}} \quad \dots(i)$

where $\lambda = \text{wavelength}$

Phase velocity $v_p = \frac{\omega}{k} \quad \dots(ii)$

From Eqs. (i) and (ii), we have

$$\Rightarrow \frac{\omega}{k} = A\lambda^{-\frac{1}{2}}$$

$$\Rightarrow \omega = Ak\lambda^{\frac{1}{2}} = \frac{Ak}{\sqrt{\lambda}}$$

$$\omega = \frac{Ak}{\sqrt{\frac{1}{k}}} \quad \omega = Ak^{\frac{3}{2}} \quad \dots(\text{iii})$$

Group velocity $v_g = \frac{d\omega}{dk}$

$$\Rightarrow v_g = \frac{d}{dk} (Ak^{\frac{3}{2}})$$

$$\Rightarrow v_g = A \frac{3}{2} k^{\frac{1}{2}}$$

$$\Rightarrow v_g = \frac{3}{2} Ak^{\frac{1}{2}}$$

$$\Rightarrow v_g = \frac{3}{2} A\lambda^{-\frac{1}{2}} = \frac{3}{2} v_p \quad (\text{By Eq. (i)})$$

$$\Rightarrow \text{Group velocity} = \frac{3}{2} v_p$$

36.(B) This circuit can be represented as also,

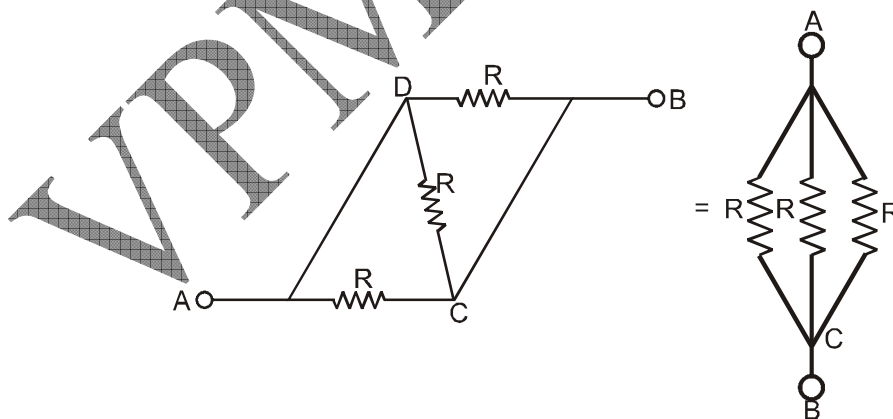

So, equivalent resistance $\frac{1}{R'} = \frac{1}{R} + \frac{1}{R} + \frac{1}{R} = \frac{3}{R}$

$$R' = \frac{R}{3}$$

When a emf. E and internal resistance r is connected between A and B then current in the

circuit $i = \frac{E}{R'+r} = \frac{E}{\frac{R}{3}+r}$

power loss in circuit $P = (i)^2 R'$

$$= \left(\frac{E}{\frac{R}{3}+r} \right)^2 \left(\frac{R}{3} \right) = \frac{E^2 \left(\frac{R}{3} \right)}{\left(\frac{R}{3}+r \right)^2}$$

$$P = \frac{E^2 \left(\frac{R}{3} \right)}{\left(\frac{R}{3}-r \right)^2 + \frac{4Rr}{3}} \quad \dots\dots(1)$$

for maximum value of p , denominator should be minimum $\frac{R}{3}-r = 0$

So, $R = 3r$

37.(B) This wave function must satisfy the differential equation :

$$-\frac{\hbar^2}{2m} \frac{d^2}{dx^2} \ddot{\Phi}_n(x) = E_n \ddot{\Phi}_n(x)$$

We replace $\Phi_n(x)$ in this equation by its expression :

$$-\frac{\hbar^2}{2m} \frac{d^2}{dx^2} \ddot{\Phi}_n(x) = -\frac{\hbar^2}{2m} \frac{d^2}{dx^2} \sqrt{\frac{2}{a}} \sin\left(\frac{n\pi}{a}x\right) = \left(\frac{n^2 \hbar^2}{2ma^2}\right) \Phi_n(x)$$

Which gives : $E_n = \frac{n^2 \hbar^2 \pi^2}{2ma^2}$

38.(B) For small r , $e^{-\alpha r}$ is unity and the field is

$$\vec{E} = \frac{q}{r^3} \hat{x}$$

and shows that there is a point charge q at the origin,

For points away from the origin, we may have $\vec{E} = \frac{qe^{-\alpha r}}{r^3} \hat{x}$ and

$$\begin{aligned} \rho &= \frac{1}{4\pi} \nabla \cdot \vec{E} + q\delta(x) \\ &= \frac{1}{4\pi} \left[q(-\alpha)e^{-\alpha r} \frac{\hat{x} \cdot \hat{x}}{r} + qe^{-\alpha r} 3 \frac{1}{r^3} - 3qe^{-\alpha r} \hat{x} \cdot \frac{\hat{x}}{r^5} + q\delta(x) \right] \\ &= -\frac{1}{4\pi} \frac{\alpha q e^{-\alpha r}}{r^2} + q\delta(x) \end{aligned}$$

The total charge is

$$= -\frac{\alpha q}{4\pi} \int_0^\infty d^3\hat{x} \frac{e^{-\alpha r}}{r^2} + q$$

$$\left[\text{we know } \int_0^\infty d^3\hat{x} \frac{e^{-\alpha r}}{r^2} = 4\pi \int_0^\infty dr e^{-\alpha r} \right] = -\alpha q \int_0^\infty dr e^{-\alpha r} + q$$

$$= -\alpha q \left[\frac{e^{-\alpha r}}{-\alpha} \right]_0^\infty + q$$

$$= -\alpha q \left[0 - \frac{1}{-\alpha} \right] + q$$

$$= -q + q = 0$$

Thus the total charge is zero.

39.(C) Heat lost by Ni = heat gained by water + Calorimeter

We know heat capacity of Ni, $C_{Ni} = 0.106 \text{ kcal/}^\circ\text{C}$

$$C_{\text{water}} = 1 \text{ K.cal/}^\circ\text{C}$$

$$C_{\text{calorimeter}} = .020 \text{ K cal/}^\circ\text{C}$$

$$\text{So, } 0.250 (0.106) (120^\circ - t) = [(0.200)(1.00 + 0.020)] \times (t - 10^\circ\text{C})$$

$$3.18 - 0.07 t = 0.220 t - 2.20$$

$$0.247t = 5.38$$

$$t = 22^\circ\text{C}$$

40.(D) Condition for stable orbit, $\frac{\partial^2 V}{\partial r^2} > 0$.

this condition gets modified to

$$\left. \frac{\partial f}{\partial r} \right|_{r=r_0} < -\frac{3f(r_0)}{r_0}$$

$$-Kn r_0^{n-1} < \frac{3(-K r_0^n)}{r_0}$$

$$-Kn r_0^{n-1} < +3 K r_0^{n-1} \Rightarrow n > -3$$

41. When the platform just starts to tilt, it will tend to rotate clockwise, pivoting about the point of attachment of the right rope. When this occurs, the left rope is slack, and there is no tension in the rope i.e. $F_1 = 0 \text{ N}$ (see diagram below)

Since the platform is in equilibrium:

$$\Sigma \tau = 0$$

Taking moments about P_2

(we choose this point because F_2

has no torque about this point as its line of action passes through it),

$$(600 \times 1.5) \text{ Nm} = (W_{\text{goods}} \times .4) \text{ Nm}$$

$$W_{\text{goods}} = 2250 \text{ N}$$

$$\text{Maximum mass of goods} = \frac{2250\text{N}}{10} = 225 \text{ kg}$$

Since the platform is in equilibrium

$$\Sigma F = 0, \text{ and } F_1 = 0\text{N}$$

$$\begin{aligned} F_2 &= W_{\text{goods}} + 600 \text{ N} \\ &= (2250 + 600) \text{ N} \\ &= 2850 \text{ N.} \end{aligned}$$

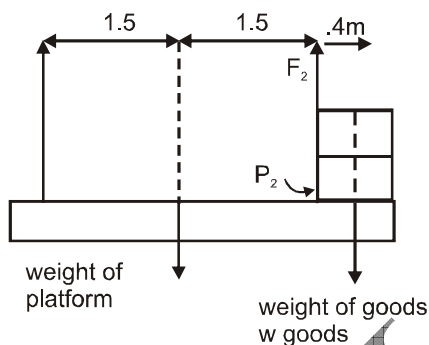

42. According to 1st law of thermodynamics,

$$\Delta Q = \Delta U + \Delta W$$

So for the vessel for which internal energy (and hence, temperature) remains constant

$$\Delta Q_1 = \Delta W = \mu RT \log_e (V_F / V_I) \quad [\text{as } \Delta U = 0] [\mu = 1]$$

$$\text{i.e., } \Delta Q_1 = 1 \times R \times 300 \log_e (2) = 0.693 \times 300R = 207.9 R$$

and for the vessel for which volume is kept const.,

$$\Delta Q_2 = \Delta U = \mu C_V \Delta T \quad [\text{as } \Delta W = 0]$$

$$\text{i.e., } \Delta Q_2 = 1(3/2) R \Delta T \quad [\text{as } C_V = (3/2) R]$$

According to given problem $\Delta Q_1 = \Delta Q_2$, i.e.,

$$207.9R = (3/2)R \Delta T, \text{ i.e., } \Delta T = 138.6$$

$$\text{i.e., } T_F - T_I = 138.6 \quad \text{with } T_I = 300 \text{ K}$$

$$\text{so } T_F = 300 + 138.6 = 438.6 \text{ K}$$

Now when the free mixing of gases is allowed

$$U_1 + U_2 = U$$

$$\mu_1(C_V)_1 T_1 + \mu_2(C_V)_2 T_2 = \mu C_V T \quad \text{with} \quad \mu = \mu_1 + \mu_2$$

Here and $(C_V)_1 = (C_V)_2 = C_V$

$$\text{so} \quad 1 \times 300 + 1 \times 438.6 = 2T, \quad \text{i.e.,} \quad T = 369.3 \text{ K}$$

Further for the mixture from $PV = \mu RT$ with $V = V + 2V = 3V$ and $\mu = \mu_1 + \mu_2 = 2$,

we have

$$P = \frac{\mu RT}{3V} = \frac{2 \times 8.3 \times 369.3}{3 \times 8.3 \times 10^{-3}} = 2.462 \times 10^5 \text{ N/m}^2$$

43. From the given equation of state, $P = \frac{RT}{V-b} - \frac{a}{V^2}$ Therefore,

$$W = \int_{V_1}^{V_2} P dV = - \int_{V_1}^{V_2} \left(\frac{RT}{V-b} - \frac{a}{V^2} \right) dV$$

$$\text{or} \quad W = -RT \ln \left(\frac{V_2 - b}{V_1 - b} \right) + \left(\frac{a}{V_1} - \frac{a}{V_2} \right)$$

$$\left(\frac{\partial U}{\partial V} \right)_T = \frac{a}{V^2}$$

$$\text{Integration both sides gives } \Delta U = \int_{V_1}^{V_2} \frac{a}{V^2} dV = a \left(\frac{1}{V_1} - \frac{1}{V_2} \right)$$

$$\text{Hence, from the first law } \Delta U = Q + W, \text{ we have } Q = \Delta U - W = a \left(\frac{1}{V_1} - \frac{1}{V_2} \right) + RT \ln$$

$$\left(\frac{V_2 - b}{V_1 - b} \right) - \left(\frac{a}{V_1} - \frac{a}{V_2} \right)$$

$$\text{or} \quad Q = RT \ln \left(\frac{V_2 - b}{V_1 - b} \right)$$

Again, by definition, $H = U + PV$. Therefore, $\Delta H = \Delta U + \Delta(PV)$.

The given equation of state can be rearranged as

$$P = \frac{RT}{V-b} - \frac{a}{V^2}$$

Now, multiplying both sides by V , we obtain $PV = RT \frac{V}{V-b} - \frac{a}{V}$

$$\text{Then, } \Delta(PV) = RT \left(\frac{V_2}{V_2-b} - \frac{V_1}{V_1-b} \right) - \left(\frac{a}{V_2} - \frac{a}{V_1} \right) = RT \frac{V_2(V_1-b) - V_1(V_2-b)}{(V_2-b)(V_1-b)} -$$

$$\left(\frac{a}{V_2} - \frac{a}{V_1} \right)$$

$$= \frac{-RTb(V_2 - V_1)}{(V_2-b)(V_1-b)} - \left(\frac{a}{V_2} - \frac{a}{V_1} \right) = \frac{-RTb[(V_2-b) - (V_1-b)]}{(V_2-b)(V_1-b)} - \left(\frac{a}{V_2} - \frac{a}{V_1} \right)$$

$$= RTb \left(\frac{1}{V_2-b} - \frac{1}{V_1-b} \right) - \left(\frac{a}{V_2} - \frac{a}{V_1} \right)$$

$$= RTb \left(\frac{1}{V_2-b} - \frac{1}{V_1-b} \right) + \left(\frac{a}{V_1} - \frac{a}{V_2} \right)$$

$$\text{Therefore, } \Delta H = \Delta U + \Delta(PV) \text{ becomes } \Delta H = RTb \left(\frac{1}{V_2-b} - \frac{1}{V_1-b} \right) + 2a \left(\frac{1}{V_1} - \frac{1}{V_2} \right)$$

44. (a) For isobaric process $P = \text{const}$

$$\text{so } \frac{T_2}{T_1} = \frac{V_2}{V_1} = \frac{2V}{V} = 2$$

$$\text{i.e., } T_2 = 2T_1 = 2 \times 300 = 600 \text{ K} \quad \dots(1)$$

So work done in isobaric process,

$$W_B = P(V_2 - V_1) = nR [T_2 - T_1] \text{ [as } PV = nRT]$$

$$W_B = 2 \times 8.3 (600 - 300) = 4980 \text{ J} \quad \dots(2)$$

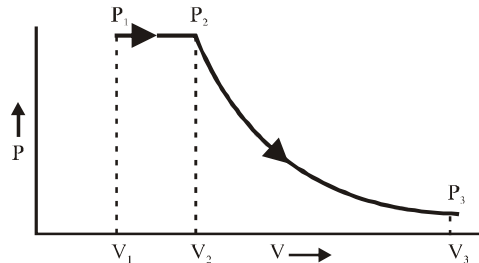

And for adiabatic process,

$$T_2 V_2^{\gamma-1} = T_3 V_3^{\gamma-1}$$

But here $T_3 = T_1 = 300 \text{ K}$, $T_2 = 600 \text{ K}$ and $V_2 = 40 \times 10^{-3} \text{ m}^3$

so $V_3 = 40 \times 10^{-3} \times (600 / 300)^{3/2} = 113.12 \times 10^{-3} \text{ m}^3$

and from gas equation $P_3 V_3 = nRT_3$,

$$P_3 = \frac{2 \times 8.3 \times 300}{113.12 \times 10^{-3}} = 0.44 \times 10^5 \text{ N/m}^2$$

(b) And as work done in adiabatic process,

$$\begin{aligned} W_A &= \frac{nR}{(1-\gamma)} (T_2 - T_1) = \frac{2 \times 8.3}{[(5/3)-1]} [600 - 300] \\ &= 3 \times 8.3 \times 300 = 7470 \text{ J} \end{aligned}$$

So in the light of Eqn. (2) the work done in the whole process

$$W_T = W_B + W_A = 4980 + 7470 = 12.450 \text{ kJ}$$

45. Final pressure will be same on both sides. Let it be P' , with volume V' in the left side and $(6V - V')$ in the right side.

(A) If the change is isothermal:

For the gas enclosed in the left chamber,

$$P \times 5V = P' V' \quad \dots(1)$$

while for the gas in the right chamber,

$$8P \times V = P' (6V - V') \quad \dots(2)$$

Solving these for V' and P' , we get

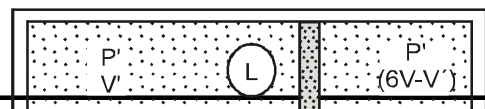
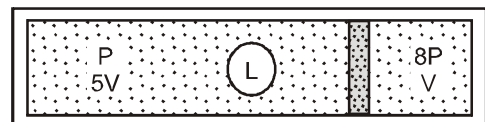

$$V' = \frac{30}{13}V \quad \text{and} \quad P' = \frac{13}{6}P$$

$$\text{and} \quad (6V - V') = \frac{48}{13}V$$

Fig.

(B) If the change is adiabatic: For the gas in the left chamber,

$$P(5V)^\gamma = P'(V)^\gamma \quad \dots(3)$$

and for the gas in the right chamber,

$$8P(V)^\gamma = P'(6V - V')^\gamma \quad \dots(4)$$

Dividing (4) by (3),

$$\left(\frac{6V - V'}{V}\right)^{3/2} = \frac{8}{5^{3/2}} \quad \text{or} \quad \frac{6V}{V'} = 1 + \frac{4}{5} \quad \text{i.e.,} \quad V' = \frac{10}{3}V$$

Substituting it in Eqn. (3),

$$P' = P \left(\frac{5V \times 3}{10V}\right)^{3/2} = \frac{3\sqrt{3}}{2\sqrt{2}}P = 1.84P$$

$$\text{so} \quad P' = 1.84P; \quad V' = \frac{10}{3}V \quad \text{and} \quad (6V - V') = \frac{8}{3}V$$

46. The x and y components of the Velocity in S'; frame are given by

$$u_x = \frac{u_x - v}{1 - u_x v / c^2}, \quad u_y = \frac{u_y \sqrt{1 - v^2 / c^2}}{(1 - u_x v / c^2)}$$

Here, $u_x = 6 \times 10^7 \cos 60^\circ = 3 \times 10^7 \text{ m/sec}$, $u_y = 6 \times 10^7 \sin 60^\circ = 3\sqrt{3} \times 10^7 \text{ m/sec}$ and $v = 3 \times 10^7 \text{ m/sec}$.

$$\text{Therefore} \quad u'_x = \frac{3 \times 10^7 - 3 \times 10^7}{1 - \frac{3 \times 10^7 \times 3 \times 10^7}{(3 \times 10^8)^2}} = 0$$

$$\begin{aligned} \text{Also, } u_y &= \sqrt{1 - \left[\frac{3 \times 10^7}{3 \times 10^8} \right]^2} \times \left[\frac{3\sqrt{3} \times 10^7}{1 - \frac{3 \times 10^7 \times 3 \times 10^7}{(3 \times 10^8)^2}} \right] \\ &= \sqrt{\frac{99}{100}} \times \frac{3\sqrt{3} \times 10^7 \times 100}{99} = \sqrt{\frac{3}{11}} \times 10^8 = 5.2 \times 10^7 \text{ m/sec} \end{aligned}$$

Hence the velocity in S' frame is

$$\mathbf{u}' = 0 + \hat{i} + 5.2 \times 10^7 \hat{j} \quad \text{or} \quad u' = 5.2 \times 10^7 \hat{j}$$

This means that the particle will appear to an observer in S' to be moving along the Y- axis with velocity 5.2×10^7 m/sec.

47. Zener break down takes place in diodes having heavily doped p and n regions with essentially narrow depletion region. Considerable reverse bias gives rise to intense electric field in the narrow depletion region causing breakdown of covalent bonds and so creating a number of electron-hole pairs which substantially add to the reverse current which may sustain at a constant voltage across the junction. This breakdown is reversible.

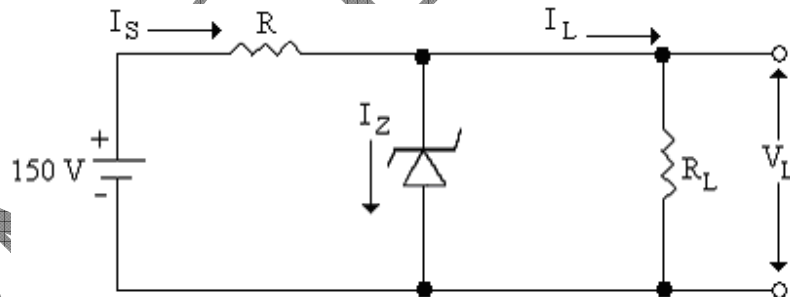

Problem:

For $I_L = 0$, $V_L = 50$ volts and

$$I_Z = I_S = (150 - 50) / R \leq 40 \text{ mA}$$

Hence $R \geq 100/40 \text{ K}\Omega$, i.e. $2.5 \text{ K}\Omega$

For $I_L = I_{\text{max}}$, $I_Z \geq 5 \text{ mA}$

But for $R = 2.5 \text{ K}\Omega$, $I_S = 40 \text{ mA}$.

$$\text{Hence } I_{\max} = 40 - 5 = 35 \text{ mA}$$

48. (a) Rest mass of the electron $m_0 = 9.028 \times 10^{-28} \text{ gm}$.

$$\therefore \text{Energy equivalent} = m_0 c^2 = 9.028 \times 10^{-28} \times (3 \times 10^{10})^2 \text{ ergs}$$

$$= 81.252 \times 10^{-8} \text{ ergs}$$

$$\text{Now one electron volt} = 1.6 \times 10^{-12} \text{ ergs}$$

\therefore Energy in electron volt

$$= \frac{81.252 \times 10^{-8}}{1.6 \times 10^{-12}} = 0.5078 \times 10^6 \text{ eV} = 0.5078 \text{ MeV}$$

(1 MeV = one million electron volts)

- (b) Atomic mass unit = $1.6558 \times 10^{-24} \text{ gm}$

$$\therefore \text{Energy equivalent} = \frac{1.6558 \times 10^{-24} \times (3 \times 10^{10})^2}{1.6 \times 10^{-12}} \text{ eV}$$

$$= 931 \times 10^6 \text{ eV} = 931 \text{ MeV}$$

49. (a) At the zone face centre $k = \frac{\pi}{a}$ and

$$\text{Energy } E = \frac{\hbar^2 k^2}{2m} \text{ Assuming totally free electron.}$$

$$= \frac{(1.05 \times 10^{-34})^2 \left(\frac{\pi}{4.85 \times 10^{-10}} \right)^2}{2 \times 9.1 \times 10^{-31}} \quad \therefore a = 4.85 \text{ \AA}$$

$$= 2.54 \times 10^{-19} \text{ J} = 1.59 \text{ eV}$$

(b) Since energy $u(G_1) = 0.24 \text{ eV}$ hence there are two distinct levels, one $|u(G_1)|$ below the free electron level given by

$$= 1.59 - 0.24 = 1.35 \text{ eV}$$

and other above the free electron level given by

$$= 1.59 + 0.24 = 1.83 \text{ eV}$$

50. In case of potential divider bias

$$V_{Th} = \left(\frac{R_2}{R_1 + R_2} \right) V_{CC} = \left(\frac{5}{5 + 100} \right) 20 = 0.952 \text{ V}$$

$$R_{Th} = \left(\frac{R_1 R_2}{R_1 + R_2} \right) = \left(\frac{5 \times 100}{5 + 100} \right) = 4.76 \text{ k}\Omega.$$

Applying the kirchoff's law to base - emitter circuit

$$V_{Th} = I_b R_{Th} + V_{br} + (I_c + I_b) R_e$$

Expressing current in mA's and resistance in k Ω 's, we have

$$0.952 = I_b \times 4.76 + 0.2 + 0.2 + 51 \times I_b \times 0.1$$

Solving we get $I_b = 0.076 \text{ mA}$

$$\begin{aligned} \therefore I_c &= \beta I_b \\ &= 50 \times 0.76 \\ &= 3.8 \text{ mA} \end{aligned}$$

Further, $V_{ce} = I_c R_c$

$$= V_{ce} + (I_c + I_b) R_e$$

$$\begin{aligned} \therefore V_{ce} &= V_{CC} - I_c R_c - (I_c + I_b) R_e \\ &= 20 - 3.8 \times 2 - 3.876 \times 0.01 \\ &= 12 \text{ V} \end{aligned}$$

So Q point is, $I_c = 3.8 \text{ mA}$ and, $V_{ce} = 12 \text{ V}$.